

**HFN Active - Pickup For Steel String Guitars - Installation Instructions**

To Install the HFN Artist you will need the following tools:  
 Electric drill, 1/2"spade or forstner bit, assorted drill bits to 1/2", x-acto, side cutters , needle nose pliers, small flat head jewellers driver.

**Important: Please read these instructions before installing the pickup system**

**Installing the Endpin Jack Preamp**

- 1) Slack off all six strings and remove them or tape them out of the way. Remove any end pin at the butt.
- 2) If the instrument had a strap button attached with a small screw, use either the spade or forstner bit to drill a pilot hole through the end block.
- 3) If the instrument had a strap button press fitted or glued into a tapered hole in the end block, you will need to gradually and carefully increase the diameter of the hole to 1/2" using either a tapered reamer or a succession of different drill bits concluding with a 1/2" size.
- 4) Remove the outer strap button, and the small nut and washer from the endpin jack.
- 5) Reach inside the sound hole and poke the endpin jack through the drilled hole in the end block. The jack should protrude approximately 5/16" outside the guitar. Reinstall the flat washer and small nut.
- 6) Insert a small allen wrench or other small round (a drill bit) through the 2 holes in the end of the endpin jack to keep the jack assembly from rotating; tighten the small nut.



Rotate Clockwise For More Gain

Circuit Board Mounted Gain Control

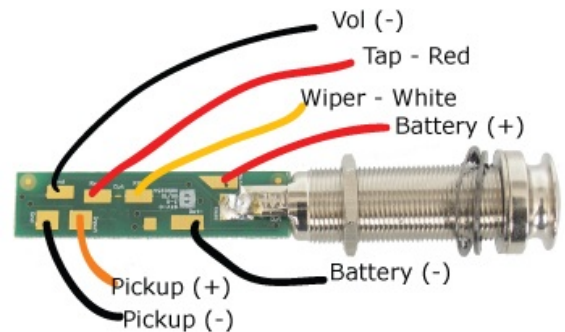

**Setting the preamp gain**

- 1) The Player endpin jack preamp is a single channel preamp. On the preamp circuit board there is a trim pot for for setting the input gain. As supplied with our HFN pickup, the preamp comes from the factory with the trim pot gain set at approximately 20 percent of maximum gain. A small jewellers screw driver may be use to rotate the trim pot. Rotating it fully counterclockwise will turn the input gain to fully off.
- 2) It may be necessary to adjust the input gain on the preamp circuit board. If the input gain is set too low the amplifier or mixer may not process the signal properly. If the input gain is set too high then distortion may occur.

**Installing the Pickup**

Ideally, the bridge plate area where the pickup is to be mounted should be almost perfectly flat. However in most cases there is some curvature to that area caused by the pulling tension of the strings on the top. For most installations this minor curvature won't affect pickup performance. But, in some cases one has to adjust pickup fit. Please read section on String Balance and Troubleshooting for more information.

- 1) The pickup is meant to go as directly under the saddle as possible(and in line with it).
  - 2) Reinstall both E string bridge pins. Make a mental note of about how far the saddle slot is from the bridge pins.
- Note: For attaching the transducer unit to the bridge plate you have the choice of using one of two different mounting options: foam tape mounting or putty mounting. The foam tape mounting is a little quicker and tidier than the putty and tends to give the most even response in most applications. The putty will transmit a little more of the highs and may be used if the instrument is dark or primarily bassy. It is suggested that you install the pickup with the foam tape to begin with.

**Foam Tape Mounting**

- 1) Remove the backing from one side of the foam tape. With the foam tape sticky side up on a flat surface, place the feet of the pickup over the tape and press down to make the tape adhere to the feet. Remove the backing from the other side of the foam tape.
- 2) Using the outside E string bridge pins for a guide, reach in through the soundhole and use your fingers to judge the centering of the pickup. Try to get it directly under the saddle if possible. Press the pickup firmly into place.

**Important: VHB tape may not be reused, it will only stick properly one time.**

**Putty Mounting**

- 1) Place a bit of putty about the size of a pea on the bottom of each foot of the pickup. Using the outside E string bridge pins for a guide, reach in through the soundhole and use your fingers to judge the centering of the pickup. Try to get it directly under the saddle if possible. Press the pickup firmly into place.

**Installing Thumbwheel Controls**

- 1) Thumbwheel controls are normally installed so that the black wheels extend just slightly beyond the edge of the soundhole on the bass side.
- 2) Feel inside your guitar, under the lip of the soundhole and find an area that is clean and flat and large enough for the control unit to

sit flat. The control unit must sit flat in order for the VHB foam adhesive to hold properly. If a large enough flat area does not exist, a small thin wood plate may have to be glued in to provide the necessary flat room between braces.

3) Remove the backing from the VHB tape and while supporting the outside area of the soundhole, firmly press the control unit into place.

### **Installing the Battery Bag**

- 1) In order to make sure that the battery wires will reach to where you want to position it, install a battery in the bag and attach the battery connector.
- 2) Chose a spot on the inside of your guitar where you would like to place the battery. Make certain that you can reach the battery through the soundhole and that both the battery and the wires can remain out of sight. Make sure that the spot you chose is relatively flat and that it is clean and dry.
- 3) Once you have confirmed the location, peel the backing from the velcro pad and press it into place.

### **Finishing Touches**

- 1) Using the supplied wire holders, clamp the battery leads and pickup lead wire so they are secure. Reinstall the strings.

### **String Balance and Troubleshooting**

Some guitars can exhibit variations in volume from string to string. These variations will usually show up as an outer string not being as loud as an inner string. The cause of these imbalances can be excessive curvature across the bridge plate or a physical out-of-phase issue within the structure of the instrument itself. Here are some things that can be done to help if you run into these problems. The pickup works by physically sampling vibration through the 3 'feet' of the pickup base. The first thing one should try is to keep the center foot of the pickup base from coming into contact with the bridge plate and this can be accomplished by using a new piece of VHB tape and only putting the tape on the outside two 'feet' of the pickup. If you are using the putty for mounting the pickup, remove the putty from the center 'foot' of the pickup and reinstall.